

X056/302

NATIONAL
QUALIFICATIONS
2000

THURSDAY, 25 MAY
10.30 AM – 12.00 NOON

**MATHEMATICS
HIGHER**
Paper 2

Read Carefully

- Calculators may be used in this paper.**
- There are three Sections in this paper.
Section A assesses the compulsory units Mathematics 1 and 2.
Section B assesses the optional unit Mathematics 3.
Section C assesses the optional unit Statistics.
Candidates must attempt **all** questions in Section A (Mathematics 1 and 2) **and**
either Section B (Mathematics 3)
or Section C (Statistics).
- Full credit will be given only where the solution contains appropriate working.
- Answers obtained by readings from scale drawings will not receive any credit.

ALL candidates should attempt this Section.

A1. The diagram shows a sketch of the graph of $y = x^3 - 3x^2 + 2x$.

(a) Find the equation of the tangent to this curve at the point where $x = 1$.

(b) The tangent at the point $(2, 0)$ has equation $y = 2x - 4$. Find the coordinates of the point where this tangent meets the curve again.

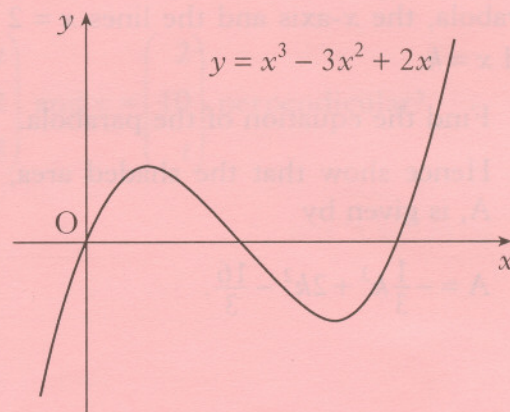

5

5

A2. (a) Find the equation of AB, the perpendicular bisector of the line joining the points $P(-3, 1)$ and $Q(1, 9)$.

(b) C is the centre of a circle passing through P and Q. Given that QC is parallel to the y-axis, determine the equation of the circle.

(c) The tangents at P and Q intersect at T.

Write down

(i) the equation of the tangent at Q

(ii) the coordinates of T.

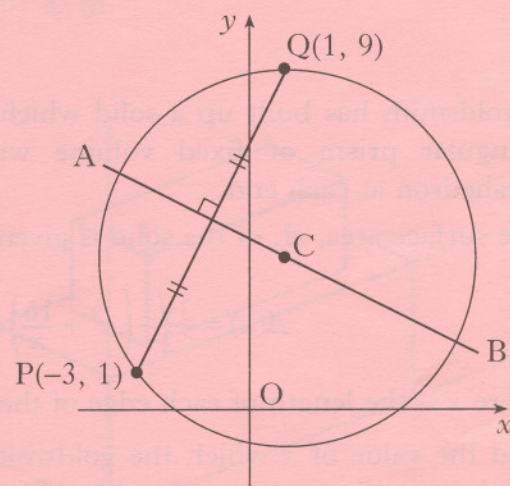

4

3

2

A3. $f(x) = 3 - x$ and $g(x) = \frac{3}{x}$, $x \neq 0$.

(a) Find $p(x)$ where $p(x) = f(g(x))$.

(b) If $q(x) = \frac{3}{3-x}$, $x \neq 3$, find $p(q(x))$ in its simplest form.

2

3

- A4.** The parabola shown crosses the x -axis at $(0, 0)$ and $(4, 0)$, and has a maximum at $(2, 4)$.

The shaded area is bounded by the parabola, the x -axis and the lines $x = 2$ and $x = k$.

- (a) Find the equation of the parabola.
 (b) Hence show that the shaded area, A , is given by

$$A = -\frac{1}{3}k^3 + 2k^2 - \frac{16}{3}.$$

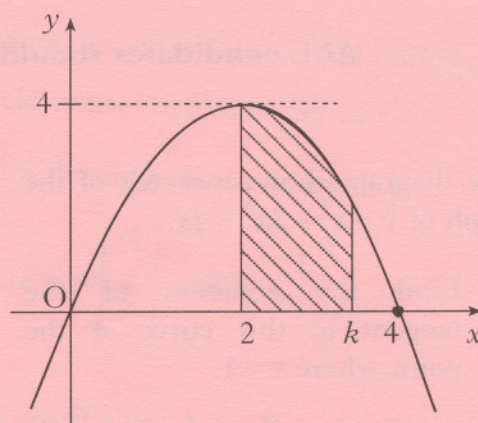

2

3

- A5.** Solve the equation $3 \cos 2x^\circ + \cos x^\circ = -1$ in the interval $0 \leq x \leq 360$.

5

- A6.** A goldsmith has built up a solid which consists of a triangular prism of fixed volume with a regular tetrahedron at each end.

The surface area, A , of the solid is given by

$$A(x) = \frac{3\sqrt{3}}{2} \left(x^2 + \frac{16}{x} \right)$$

where x is the length of each edge of the tetrahedron.

Find the value of x which the goldsmith should use to minimise the amount of gold plating required to cover the solid.

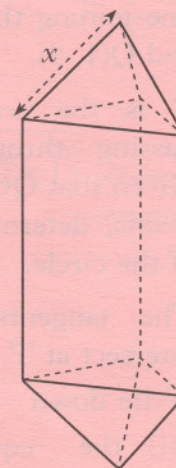

6

[END OF SECTION A]

Candidates should now attempt

EITHER Section B (Mathematics 3) on Pages five and six

OR Section C (Statistics) on Pages seven and eight

ONLY candidates doing the course Mathematics 1, 2 and 3 should attempt this Section.

B7. For what value of t are the vectors $u = \begin{pmatrix} t \\ -2 \\ 3 \end{pmatrix}$ and $v = \begin{pmatrix} 2 \\ 10 \\ t \end{pmatrix}$ perpendicular? 2

B8. Given that $f(x) = (5x - 4)^{\frac{1}{2}}$, evaluate $f'(4)$. 3

- B9. A cuboid measuring 11 cm by 5 cm by 7 cm is placed centrally on top of another cuboid measuring 17 cm by 9 cm by 8 cm. Coordinate axes are taken as shown.

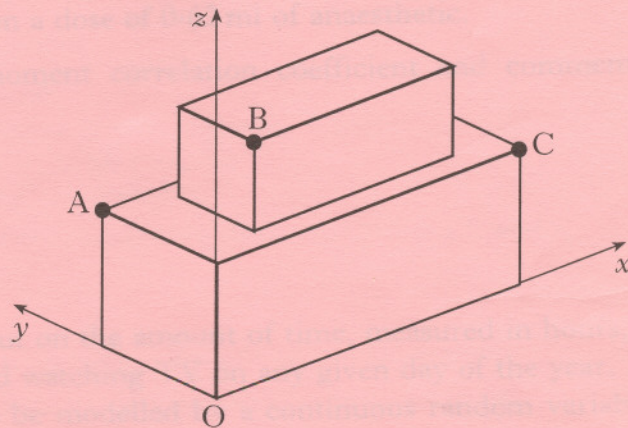
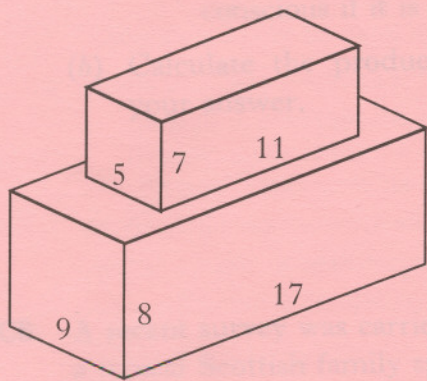

- (a) The point A has coordinates $(0, 9, 8)$ and C has coordinates $(17, 0, 8)$.
Write down the coordinates of B. 1
- (b) Calculate the size of angle ABC. 6

[Turn over

B10. Find $\int \frac{1}{(7-3x)^2} dx$.

B11. The results of an experiment give rise to the graph shown.

(a) Write down the equation of the line in terms of P and Q .

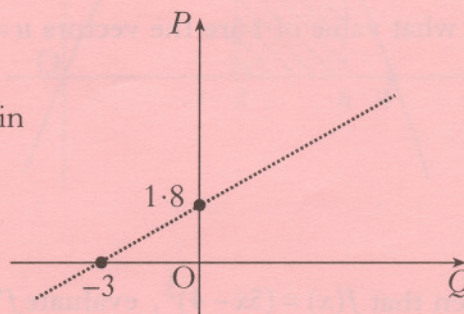

It is given that $P = \log_e p$ and $Q = \log_e q$.

(b) Show that p and q satisfy a relationship of the form $p = aq^b$, stating the values of a and b .

[END OF SECTION B]