

## Similarity (Exam Type Questions)

1. The diagram below shows two candles. Each candle is in the shape of a cuboid with a square base.

The length of time each candle will burn is proportional to its volume.

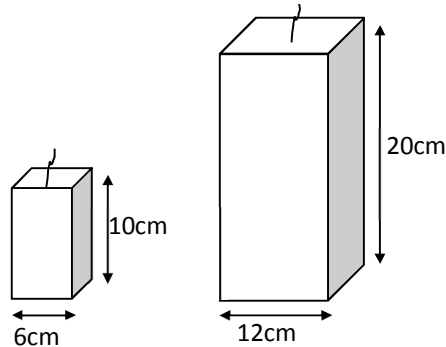

The small candle burns for 36 hours.

Nadia reckons that because the large candle's measurements are double the small candle's measurements then the large candle should burn for 72 hours.

Is she correct? [You should show all working and give a reason for your answer]

2. An international perfume manufacturer prices their bottles of perfume **by volume**.

The two bottles below, although containing different volumes, are mathematically similar in shape. Their heights and prices are shown.



The larger of the two bottles is for sale in France.

Assuming the smaller bottle to be priced correctly, determine whether or not the larger bottle has the correct price tag given that the exchange rate is  $\text{£}1 = 1.10$  euros.

3. John is looking to buy a new rug for his main room.

The two rugs below are **mathematically similar** in shape.

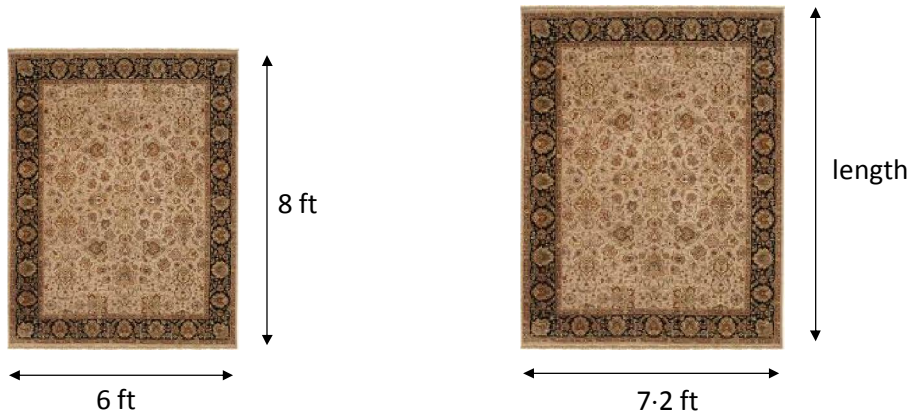

He is hoping that the length of the large rug will be enough to make the **area** of the large rug **at least 72 square feet**.

Does the large rug have the required area?

**You must show appropriate working with your answer.**

4. In the diagram below triangles ABC and ADE are **mathematically similar**.

BC = 12 cm, DE = 9 cm and AE = 21 cm.

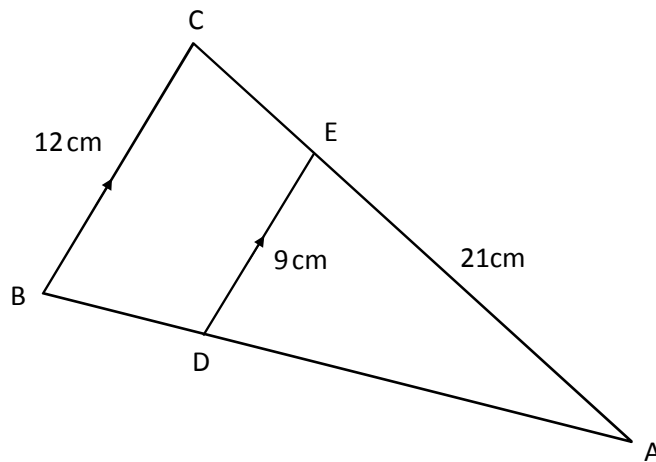

Find the length of CE.